

# ALABAMA homebuilder

A QUARTERLY PUBLICATION OF THE HOME BUILDERS ASSOCIATION OF ALABAMA  
VOL 9 | No.3 | FALL 2014

## Take It Outside - Outdoor Living



Outdoor fireplace system by Isokern

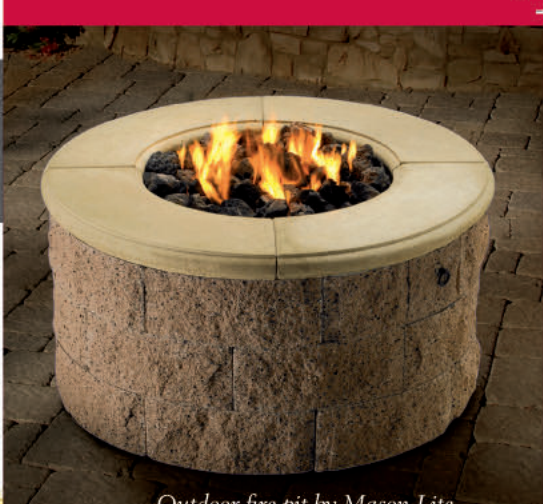

Outdoor fire pit by Mason-Lite

### 10 Alabama Locations

**Albertville**  
5623 Hwy 431 S  
Albertville, AL 35950  
256-878-7177 • brick.com/AVO

**Attalla**  
532 Gilbert Ferry Road SE  
Attalla, AL 35954  
256-538-2212 • brick.com/AAS

**Birmingham**  
2299 Pelham Parkway  
Pelham, AL 35124  
205-988-3913 • brick.com/BIS

**Dothan**  
2535 Ross Clark Circle  
Dothan, AL 36301  
334-677-0081 • brick.com/DOS

**Florence**  
502 Veterans Drive  
Florence, AL 35630  
256-766-6448 • brick.com/FLS

**Huntsville**  
8621 Madison Blvd.  
Madison, AL 35758  
256-461-7233 • brick.com/HVS

**Mobile**  
2180 Avenue C  
Brookley Complex  
Mobile, AL 36615  
251-433-5569 • brick.com/MBS

**Montgomery**  
10200 Highway 80 E  
Montgomery, AL 36117  
334-215-5700 • brick.com/MGS

**Scottsboro**  
105 Liberty Lane  
Scottsboro, AL 35769  
256-259-1691 • brick.com/SBO

**Tuscaloosa**  
1168 Whigham Place  
Tuscaloosa, AL 35405  
205-759-5400 • brick.com/TLS

**M**ore and more these days, homeowners are looking to add outdoor rooms for entertaining and recreation on their properties. That's according to the 2013 Residential Landscape Architecture Trends survey conducted by the American Society of Landscape Architects.

How will you capitalize on the move to outdoor living? See the experts at Acme Brick Tile & Stone, formerly Jenkins Brick & Tile.

Acme carries all the materials you need to build beautiful masonry enclosures for outdoor-living features such as fireplaces, fire pits, grills, and kitchens. We also stock fireplace and fire pit systems, from manufacturers such as Isokern, Fire Rock and Mason-Lite. And don't stop there.

Build patios and walkways using quality clay brick pavers from Acme Brick, Yankee Hill, Pine Hall, and others, plus sturdy concrete pavers. To terrace or contour your yard – front or back – Acme offers concrete segmental retaining wall units.

Ready to take the next step in home design? Take it outside, with support from your nearest Acme Brick Tile & Stone location.



a Berkshire Hathaway company

## THE WINNING MORTGAGE OPTION

ALABAMA HOME BUYER INITIATIVE

AHFA's *Step Up* mortgage program offers 30-year, fixed rates and down payment assistance with **no PMI costs** through the *Alabama Home Buyer Initiative*.

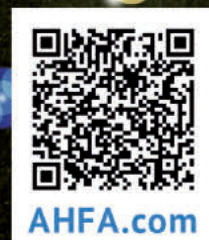

AHFA.com

**ALABAMA HOUSING  
FINANCE AUTHORITY**

*Come on home, Alabama.*

## Rewriting HISTORY

Read about this industrial remodel on page 16.



AFTER

**REWRITING HISTORY  
STAYING TRUE TO ITS ROOTS**  
ALL PHOTOS COURTESY OF HILLWORKS

A nearly century-old commercial building in downtown Auburn got a new lease on life as a home for a young family while staying true to its historic and industrial roots. Check out the transformation by Lee County Home Builders Association member HF&L Construction, Inc. beginning on page 16.



BEFORE

New windows and raw steel panels bring the exterior of the 1920 structure up to date.



## The Original Radiant Barrier Is Also The #1 Brand Among Builders.

**More Than 15 Years On The Market, Installed In Over A Million Homes.**

LP® TechShield® Radiant Barrier Sheathing is designed to reduce temperatures in the attic by up to 30° F. LP TechShield sheathing can lower monthly cooling costs by up to 17% and may reduce the required tonnage of a home's HVAC system. It installs like conventional sheathing, requiring no additional labor costs. So if you're looking for a smart way to beat the Alabama heat while saving energy, build with LP TechShield Radiant Barrier Sheathing.

Without LP® TechShield® Radiant Barrier Sheathing



Radiant heat transferred through conventional roof sheathing panels.

With LP® TechShield® Radiant Barrier Sheathing

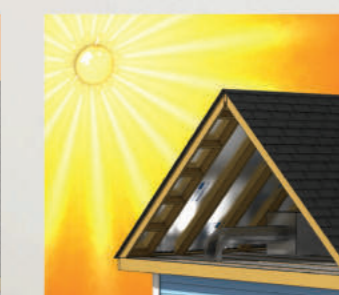

LP® TechShield® Radiant Barrier Sheathing blocks up to 97% of the radiant heat in the panel from radiating into the attic.



For more information,  
please call 888-820-0325  
or visit [LPTechShield.com](http://LPTechShield.com).

LP Corp.com **BUILD WITH US.**

OSB | SmartSide® | SolidStart® | TopNotch® | TechShield® | CanExel® | FlameBlock®



Home Builders Association  
of Alabama

Russell Davis, CAE, BIAE,  
*Executive Vice President*

Lisa Watkins,  
*Editor*

Design & Printing  
*Walker360*

7515 Halcyon Summit Dr.,  
Suite 200  
Montgomery, AL 36117

P.O. Box 241305  
Montgomery, AL 36124-1305  
334.834.3006 / 800.745.4222  
[www.hbaa.org](http://www.hbaa.org)

POSTMASTER: Send address changes  
to Alabama Homebuilder,  
P.O. Box 241305  
Montgomery, AL 36124-1305

*Published quarterly by the Home Builders Association of Alabama for Alabama's Building Professionals. Periodicals Postage Paid, through issue USPS #019-135, ISSN: 1931-7654, Montgomery, AL. Annual subscription rate for members of the association is \$3.50 per year, which is included in the dues.*

Copyright 2014 by the Home Builders Association of Alabama, Inc. All rights reserved. Reproduction in whole or part is prohibited without written authorization.

The opinions expressed in articles in Alabama Homebuilder are the opinions of the authors and do not necessarily reflect the policies of the Home Builders Association of Alabama. Furthermore, this publication does not establish due diligence on authors and does not guarantee the credibility of their offerings or writings.

# cover pullout

## COMMERCIAL BUILDING TURNED HOME



Rewriting History:  
Staying True to Its Roots

## departments

- 10 HBAA NEWS
- 12 LOCAL HBA NEWS
- 34 EDUCATION
- 37 CALENDAR

## on the cover

*A nearly century-old industrial space in Auburn gets a new lease on life as a residence for a young, growing family.*



# P E R S P E C T I V E

It's time to get in the game!

Fall's here and the college football season is just a few weeks underway, but the HBAA's "season" has been going strong since January. We've been talking football all year long, as this year's membership theme has centered around the gridiron. I'd like to commend our regional coaches and local quarterbacks for their leadership throughout the year. As you saw at our Summer Meeting in July, our coaches are as fired up as ever about increasing membership and making our association stronger.



As we enter our final quarter, I want you to know that it's not too late to get in the game. There's still time to recruit new members and increase your odds of winning cash and other prizes, including a pair of tickets to the 2014 Iron Bowl, which will be awarded at our Annual Convention in Point Clear. If you've been sitting on the sidelines, it's time for you to suit up and get in the membership game!

Speaking of our Convention, I hope you're making plans to join us for it November 6-8 at the Grand Marriott Resort in Point Clear. Our statewide meetings give us a chance to catch up with and learn from each other while making some great memories in the process. We've had some outstanding education offered at all of our meetings throughout the year, and I'm excited about the session we've got planned for Convention. It will feature a panel discussion of builders and associates sharing their best tips for saving money, making money and increasing productivity. I'm confident that you'll come away with some ideas that you can take back and implement in your business.

We'll also take time at the Convention to celebrate a momentous event in our history—the 30th anniversary of the Alabama Home Builders Self Insurers Fund. The Fund began on October 1, 1984 with just a small core group of members who committed to creating a Fund to provide affordable workman's comp coverage at a time when no one wanted to insure the home building industry. Today, the Fund serves more than 5,200 members and has given back a total of \$225 million in dividends and safety credits to eligible members. The Fund has proven to be an incredibly valuable asset and one of our most powerful tools for member recruitment and retention. It is definitely worthy of a grand celebration, and we look forward to celebrating with all of you at Convention.

We've got other fun activities planned for Convention, including a pheasant hunt, a shopping excursion to Fairhope, and our annual Hall of Fame, President's Awards and Officer Installation Banquet. We'll wrap things up with an early board meeting on Saturday morning to give you a chance to get back home or to enjoy the rest of your weekend on your own at the Grand. If you haven't yet registered for Convention, do so now—just visit [www.hbaa.org](http://www.hbaa.org) to view the schedule and to register.

Enjoy your fall, and we'll see you at Point Clear in November!

A handwritten signature in black ink, appearing to read "Les Letlow". The signature is fluid and cursive.

Les Letlow

2014 HBAA President

# DON'T GET LEFT OUT IN THE COLD

**Make sure you're hiring a licensed contractor!**

Using an unlicensed contractor for HVAC installations can leave you with no recourse should the system fail or prove inadequate. Contractors licensed by us are professionals who meet a set of standards designed to protect you and your investment.

So make sure. Visit our web site or call toll-free to find licensed contractors near you.

**(866) 855-1912**

[www.hacr.alabama.gov](http://www.hacr.alabama.gov)

**State of Alabama Board of Heating, Air  
& Refrigeration Contractors**

8 Commerce St., Ste 200

P.O. Box 305025

Montgomery, AL 36130-5025



# HOUZZ, HGTV AND "CHOPPED" AMONG SUMMER MEETING HIGHLIGHTS

With more than 600 in attendance, this year's HBAA Summer Meeting attracted its largest crowd in years. Education including sessions by experts from Houzz and HGTV proved to be extremely popular, drawing large crowds and lots of positive feedback.

Also popular were the special events, including the Thursday night welcome reception, the Friday night dinner/dance and the Saturday night BBQ Bash that featured carnival games and the HBAA's own version of the Food Network TV show "Chopped". The Blue Team (Robert Brown of Baldwin County HBA and Leisa Ratcliffe of Greater Montgomery HBA), Green Team (Steve Steele of Huntsville/Madison County BA and Carol Smith of Shoals HBA) and Red Team (Wrendon Davis of Greater Birmingham AHB and Fleta Edwards of HBA of Tuscaloosa) were each paired with a hotel employee to produce dishes using their "mystery" basket ingredients. Willy Hendrix of the Cullman County HBA and Lonny Williams of the Huntsville/Madison County BA and Greater Birmingham AHB, along with HBAA First Lady Linda Letlow, served as the "Chopped" judges. At the end of the competition, the Blue Team claimed the title of "HBAA Chopped Champions".



Mike Kelley of Counter Dimensions explains to the Public Relations Committee how his company uses Houzz as a communications and brand-building tool.



The dance floor stayed crowded at the always-popular Friday night dinner/dance.



With a little help from the South Walton High School cheerleaders, the Membership Team gets the crowd pumped up during the board meeting.



Green Team members Steve Steele (far left) and Carol Smith discuss the strategy for using their mystery basket ingredients in their dish.



Members of the Greater Morgan County Builders Association visit during the Thursday evening welcome reception. (Photo courtesy of Greater Morgan County BA)



Members of the Huntsville/Madison County Builders Association enjoy the Friday night dinner/dance.



The Blue, Green and Red Teams prepare for a showdown during the HBAA's version of "Chopped".



Wearing colored leis to show support for their favorite teams, the audience members cheer on the "Chopped" contestants.



Judges Willy Hendrix, Linda Letlow and Lonny Williams get ready to sample the dishes in the "Chopped" competition.

*The HBAA would like to thank its 2014 HBAA Summer Meeting Major Sponsors for helping to make this year's meeting such a success:*

ALABAMA HOME BUILDERS  
SELF INSURERS FUND

ALABAMA HOUSING  
FINANCE AUTHORITY

ALABAMA POWER COMPANY

ALAGASCO

BONDED BUILDERS  
WARRANTY GROUP

BORAL BUILDING PRODUCTS

CARLISLE MEDICAL, INC.

CARR, RIGGS & INGRAM

CONSTRUCTION CLAIMS  
MANAGEMENT

ARTHUR J. GALLAGHER &  
COMPANY

GENWORTH MORTGAGE  
INSURANCE

HUIE, FERNAMBUCQ & STEWART

THOMPSON INSURANCE

TOUCHSTONE ENERGY  
COOPERATIVES

TRUSTMARK BANK

WILMER & LEE, PA

# POWER TO THEIR DREAM HOME

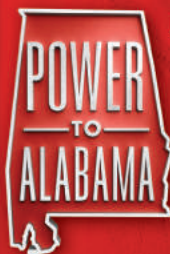

Homes that save your clients money and keep them comfortable for years to come — what more could you ask for? An all-electric home, one with both an energy-efficient electric heat pump and an electric water heater, will help your clients save money while staying comfortable. Call 1.800.990.APCO (2726) or visit [AlabamaPower.com](http://AlabamaPower.com) to find more solutions that give you the power to save.

© 2014 Alabama Power Company

  [AlabamaPower.com](http://AlabamaPower.com)

**ALABAMA  
POWER**  
A SOUTHERN COMPANY

Always on.™

## HBAA SAYS GOODBYE TO PAST PRESIDENT AWTREY

The HBAA is mourning the loss of longtime member Al Awtrey, who passed away on August 6. A native of Birmingham, Awtrey was a decorated World War II veteran

who worked as a firefighter upon his return home before entering the home building industry. He started his first building company in 1959 and joined the Greater Birmingham Association of Home Builders in 1961.

Awtrey was the first GBAHB builder member to achieve "Super Spike" status,



Al Awtrey

having recruited more than 250 members. In 1964, he constructed the first "scholarship house" in the Birmingham Parade of Homes, in which the proceeds were used to fund a scholarship for a deserving recipient. He served as GBAHB President in 1968 and was inducted into the GBAHB Hall of Fame in 1986. The GBAHB annually presents the Al Awtrey Builder of the Year Award in recognition of the association's outstanding builder.

At the state level, Awtrey served as HBAA President in 1975 and was among the first group of inductees in the Alabama Home Builders Hall of Fame in 1988. He was also extremely active within the National Association of Home Builders, serving as a National Life Director and a member of the National Housing Board.

Awtrey was extremely active in civic activities related to housing, heading up the Partnership for Assistance to the Homeless and serving as Chairman of Birmingham's Housing and Zoning Commission. In 2009, he was honored for his service to his community with the Freedom Award from the city of Hoover.

Awtrey was preceded in death by his eldest son, Albert Lawrence (Larry) Awtrey, who was also a member of the GBAHB. The HBAA extends its sympathies to Awtrey's family and friends, including his daughter, Donna Awtrey Trapp, his son, Russell Scott Awtrey, and his grandchildren and great grandchildren.

## HBAA MOURNS LOSS OF LONGTIME EO WHELOCK

The HBAA is mourning the loss of Elizabeth Alston Shivers Wheelock, who passed away on September 20. Wheelock served as the Executive Officer for the Home Builders Association of Dothan & the Wiregrass Area from 1981 to 2009. Throughout her 28-year tenure, the Dothan association grew from 99 members to nearly 500 members and won numerous awards, including the HBAA President's Trophy six times. She was instrumental in building the Dothan association's scholarship program, which has helped hundreds of students. Upon her retirement a scholarship was established in her name.

A native of Marion, Wheelock graduated from Judson College and was a resident of Dothan for most of her adult life. She was a longtime advocate of causes such as the Special Olympics, the Dothan Botanical Gardens, the Salvation Army, Habitat for Humanity and the Girls Club. She spearheaded many projects at the Vivian B. Adams School in Ozark, including a greenhouse project where students enjoyed hands-on learning about gardening and flowers.

Wheelock was preceded in death by her parents, her husband, Hugh Franklin Wheelock, Sr. and a sister, Mildred Shivers Sheen. The HBAA extends its sympathy to Wheelock's friends and family, including her three children, Hugh F. Wheelock, Jr., Laurin Wheelock and Lewitt



Elizabeth Wheelock

Shivers Wheelock; her sister, Frances Shivers Cleverdon; brother and sister-in-law, William Lewitt Shivers, Jr. and Kathy Shivers; and numerous cousins, nieces and nephews. Memorial contributions may be made in her honor to the Vivian B. Adams School, the HBA of Dothan & the Wiregrass Area's Scholarship Fund, or the Salvation Army.

## OSHA ANNOUNCES NEW REQUIREMENTS FOR REPORTING SEVERE INJURIES

The U.S. Department of Labor's Occupational Safety and Health Administration has announced a final rule requiring employers to notify OSHA when an employee is killed on the job or suffers a work-related hospitalization, amputation or loss of an eye. The rule, which also updates the list of employers partially exempt from OSHA record-keeping requirements, will go into effect on January 1, 2015 for workplaces under federal OSHA jurisdiction.

Under the revised rule, employers will be required to notify OSHA of any work-related fatalities within eight hours (same as before), and for a single employee, any work-related in-patient hospitalizations, amputations or losses of an eye within 24 hours. Previously, OSHA's regulations required an employer to report fatalities and in-patient hospitalizations of three or more employees. Reporting single hospitalizations, amputations or loss of an eye was not required under the previous rule.

All employers covered by the Occupational Safety and Health Act, even those who are exempt from maintaining injury and illness records, are required to comply with OSHA's new severe injury and illness reporting requirements. To assist employers in fulfilling these requirements, OSHA is developing a Web portal for employers to report incidents electronically, in addition to the phone reporting options.

"Hospitalizations and amputations are sentinel events, indicating that serious hazards are likely to be present at a workplace and that an intervention is warranted to protect the other workers at the establishment," said Dr. David Michaels, assistant secretary of labor for occupational safety and health.

The Alabama Home Builders Self Insurers Fund offers loss control services to make sure that your jobsite is safe and up-to-date on the latest OSHA requirements. For more information about these services, contact the Fund's Loss Control Department at 1-800-745-3863 or email [sherryjohnson@hbaa.org](mailto:sherryjohnson@hbaa.org).



## FUND TRUSTEES ANNOUNCE \$15 MILLION DIVIDEND

The Trustees of the Alabama Home Builders Self Insurers Fund recently approved a \$15 million dividend for qualifying Fund members. More than 76% of Fund members were eligible for the dividend this year. In the past two years, between dividends and safety credits, the Fund has returned more than \$40 million to qualifying members.

The Fund, which will mark its 30th anniversary on October 1, 2014, is exclusively for members of the HBAA. To learn more about membership in the Fund and to find a broker in your area, call 1-800-745-3863 or visit [www.ahbfund.com](http://www.ahbfund.com). You can also read more about the Fund on page 21 in this issue.

## GET EDUCATION ON THE GO WITH NEWLY REDESIGNED BUILDER UNIVERSITY

The HBAA's online education portal, Builder University, has recently been redesigned to give users more flexibility in how they access education. The site offers a variety of educational courses that HBAA members can take from the convenience of their desktop and laptop computers, as well as on their mobile devices, including iPhones, iPads and Droid tablets. Visit [www.BuilderUniversity.org](http://www.BuilderUniversity.org) or contact HBAA Education Director Kory Boling (1-800-745-4222 or [koryboling@hbaa.org](mailto:koryboling@hbaa.org)) to learn more.

For more information about upcoming educational offerings, see page 34 in this issue.

## BAR, PREP COURSES NOW AVAILABLE ONLINE

The National Association of Home Builders (NAHB) is now offering its BAR (Builder Assessment Review) and PREP (Professional Remodeler Experience Profile) assessments online. The BAR and PREP are pre-requisites for earning the Certified Graduate Builder (CGB) and Certified Graduate Remodeler (CGR) designations, respectively. Previously only offered in person, the BAR and PREP may now be taken from the convenience of your home or office, with results available within 24 hours of completing the assessment. For more information, visit [www.NAHB.org](http://www.NAHB.org).

## BOOTH SALES UNDERWAY FOR 2015 ALABAMA'S BETTER LIVING EXPO

Have a product or service that promotes green building, sustainability or energy efficiency? Act fast to reserve space in the 2015 Alabama's Better Living Expo (ABLE), taking place February 17-18 at the Montgomery Renaissance Convention Center in Montgomery. Held in conjunction with the HBAA's Winter Meeting, ABLE is the state's premier conference on sustainable building for the residential and commercial construction industries.

In addition to over 100 hours of education, ABLE features a trade show to showcase the latest and most innovative building products and services while giving vendors one-on-one time with key leaders and decision makers in the building industry. Booth sales are underway and space is limited, so if you're interested in reserving your spot, contact Artemis Moore at 1-800-745-4222 or email [artemis@hbaa.org](mailto:artemis@hbaa.org).

1. Publication Title		2. Publication Number		3. Filing Date	
Alabama Homebuilder		0 0 1 9 - 1 3 5		Sept. 3, 2014	
4. Issue Frequency		5. Number of Issues Published Annually		6. Annual Subscription Price	
Quarterly		4		\$3.50	
7. Complete Mailing Address of Known Office of Publication (Not printer) (Street, city, county, state, and ZIP+4®)				Contact Person	
None				Lisa Watkins	
8. Complete Mailing Address of Headquarters or General Business Office of Publisher (Not printer)				Telephone (Include area code)	
Home Builders Association of Alabama, 7515 Halcyon Summit Dr., Suite 200 Montgomery, AL 36117				334-834-3006	
9. Full Names and Complete Mailing Addresses of Publisher, Editor, and Managing Editor (Do not leave blank)					
Publisher (Name and complete mailing address)					
Home Builders Association of Alabama, 7515 Halcyon Summit Dr., Suite 200 Montgomery, AL 36117					
Editor (Name and complete mailing address)					
Lisa Watkins, 7515 Halcyon Summit Dr., Suite 200, Montgomery, AL 36117					
Managing Editor (Name and complete mailing address)					
None					
10. Owner (Do not leave blank. If the publication is owned by a corporation, give the name and address of the corporation immediately followed by the names and addresses of all stockholders owning or holding 1 percent or more of the total amount of stock. If not owned by a corporation, give the names and addresses of the individual owners. If owned by a partnership or other unincorporated firm, give its name and address as well as those of each individual owner. If the publication is published by a nonprofit organization, give its name and address.)					
Full Name		Complete Mailing Address			
Home Builders Association of Alabama		7515 Halcyon Summit Dr., Suite 200, Montgomery, AL 36117			
11. Known Bondholders, Mortgagees, and Other Security Holders Owning or Holding 1 Percent or More of Total Amount of Bonds, Mortgages, or Other Securities. If none, check box <input checked="" type="checkbox"/> None					
Full Name		Complete Mailing Address			
12. Tax Status (For completion by nonprofit organizations authorized to mail at nonprofit rates.) (Check one)					
The purpose, function, and nonprofit status of this organization and the exempt status for federal income tax purposes:					
<input checked="" type="checkbox"/> Has Not Changed During Preceding 12 Months					
<input type="checkbox"/> Has Changed During Preceding 12 Months (Publisher must submit explanation of change with this statement)					
PS Form 3526, July 2014 (Page 1 of 4 (see instructions page 4)) PSN: 7530-01-000-9031 PRIVACY NOTICE: See our privacy policy on <a href="http://www.usps.com">www.usps.com</a> .					

13. Publication Title		14. Issue Date for Circulation Data Below	
Alabama Homebuilder		Summer 2014	
15. Extent and Nature of Circulation		Average No. Copies Each Issue During Preceding 12 Months	No. Copies of Single Issue Published Nearest to Filing Date
a. Total Number of Copies (Net press run)		9,913	9,600
b. Paid Circulation (By Mail and Outside the Mail)	(1) Mailed Outside-County Paid Subscriptions Stated on PS Form 3541 (Include paid distribution above nominal rate, advertiser's proof copies, and exchange copies)	0	0
	(2) Mailed In-County Paid Subscriptions Stated on PS Form 3541 (Include paid distribution above nominal rate, advertiser's proof copies, and exchange copies)	8,910	8,708
	(3) Paid Distribution Outside the Mails Including Sales Through Dealers and Carriers, Street Vendors, Counter Sales, and Other Paid Distribution Outside USPS®	0	0
	(4) Paid Distribution by Other Classes of Mail Through the USPS (e.g., First-Class Mail®)	50 approx.	50 approx.
c. Total Paid Distribution (Sum of 15b (1), (2), (3), and (4))		8,960	8,758
d. Free or Nominal Rate Distribution (By Mail and Outside the Mail)	(1) Free or Nominal Rate Outside-County Copies included on PS Form 3541	0	0
	(2) Free or Nominal Rate In-County Copies Included on PS Form 3541	0	0
	(3) Free or Nominal Rate Copies Mailed at Other Classes through the USPS (e.g., First-Class Mail)	100 approx.	100 approx.
	(4) Free or Nominal Rate Distribution Outside the Mail (Carriers or other means)	0	0
e. Total Free or Nominal Rate Distribution (Sum of 15d (1), (2), (3) and (4))		100	100
f. Total Distribution (Sum of 15c and 15e)		9,060	8,858
g. Copies not Distributed (See Instructions to Publishers #4 (page #3))		853	742
h. Total (Sum of 15f and g)		9,913	9,600
i. Percent Paid (15c divided by 15f times 100)		98.9%	98.9%

\* If you are claiming electronic copies, go to line 16 on page 3. If you are not claiming electronic copies, skip to line 17 on page 3.

16. Electronic Copy Circulation		Average No. Copies Each Issue During Preceding 12 Months	No. Copies of Single Issue Published Nearest to Filing Date
a. Paid Electronic Copies			
b. Total Paid Print Copies (Line 15c) + Paid Electronic Copies (Line 16a)			
c. Total Print Distribution (Line 15f) + Paid Electronic Copies (Line 16a)			
d. Percent Paid (Both Print & Electronic Copies) (16b divided by 16c x 100)			
<input type="checkbox"/> I certify that 50% of all my distributed copies (electronic and print) are paid above a nominal price.			
17. Publication of Statement of Ownership			
<input checked="" type="checkbox"/> If the publication is a general publication, publication of this statement is required. Will be printed in the <b>Fall 2014</b> issue of this publication.			
<input type="checkbox"/> Publication not required.			
18. Signature and Title of Editor, Publisher, Business Manager, or Owner			Date
			September 3, 2014
Executive Vice President			
I certify that all information furnished on this form is true and complete. I understand that anyone who furnishes false or misleading information on this form or who omits material or information requested on the form may be subject to criminal sanctions (including fines and imprisonment) and/or civil sanctions (including civil penalties).			

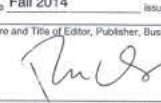
# LOCAL HBA NEWS

## SPEED COUNTS AT GBAHB FAST PITCH EVENT

The Greater Birmingham Association of Home Builders' Remodelers and Professional Women in Building recently co-hosted the inaugural Fast Pitch event at the GBAHB office. Fast Pitch is a speed networking event designed to provide GBAHB associate members with a unique one-on-one opportunity to pitch their company's product to builder members. There were 17 associate companies, represented by one or two of their employees, and 18 builder/remodeler companies present.



Associate members get five minutes to make their pitch to builders attending GBAHB's Fast Pitch speed networking event.

The associates paid to participate, but this event was free for builders and remodelers. Each associate was stationed at their own table to showcase their products and promotional materials. The builders moved from one table to the next, visiting each associate. They had five minutes to talk and then the bell rang signaling the end of that session. Before the program began and after it ended, the participants had free time for casual networking.



## BALDWIN COUNTY, MOBILE FACE OFF IN "BATTLE OF THE BAY"

For the second year in a row, members from the Baldwin County Home Builders Association and Home Builders Association of Metro Mobile met up for the "Battle of the Bay" bowling tournament. Held at Eastern Shore Lanes in Spanish Fort, the tournament combined fun, food and networking. A total of 24 teams (12 from each association) competed, with the team from Knockout Pest Control repeating as champions and earning BCHBA another year of bragging rights.

HBAA President Les Letlow presents the "Battle of the Bay" trophy to the team from Knockout Pest Control and BCHBA President Chris Price.

## MOBILE MEMBERS ENJOY DRAWDOWN EVENT

The Home Builders Association of Metro Mobile recently held a drawdown as a fundraiser for ABPAC. Hosted by Chavis Furniture, the event drew a large crowd to enjoy the food and fellowship. At the end of the night, five members-- Robert Dueitt, Miranda Wilder, Lynn Nolen, Melanie Hildesheim, and Joe Vinson—split the winnings.

Robert Dueitt, Miranda Wilder, Lynn Nolen, Melanie Hildesheim and Joe Vinson celebrate their winnings in the HBAMM's drawdown.



## CONGRESSWOMAN ROBY SPEAKS TO DOTHAN MEMBERS

The Home Builders Association of Dothan & the Wiregrass Area recently hosted Congresswoman Martha Roby at their general membership meeting. The Congresswoman discussed regulations affecting the building industry, and also spoke about the state of the Veterans' Affairs department. A questions and answer session at the end of her speech gave members the opportunity to share their own concerns with Congresswoman Roby firsthand.

HBA of Dothan & the Wiregrass Area President Matt Anderson and HBAA President Les Letlow welcome Congresswoman Martha Roby to Dothan.

## HBAMM TEES OFF FOR PRESIDENT'S CUP GOLF TOURNAMENT

The Home Builders Association of Metro Mobile drew 72 players to its recent President's Cup Golf Tournament at the Azalea City Golf Course. Before the tournament, many tested their shots on the Chipping Contest, which involved attempting to chip a golf ball into a porta-potty donated by Joe Fesenemeier of Gotta Go Portables. Steve Greene walked away as the winner.

The team from Daniel's Sheetmetal took home first place in the golf tournament, with second place going to the Mainstreet Flooring team and third place to the Ford Lumber team.

HBAMM members Eric Brewer, Joe Hocklander, Neal Price and Kelley Ouzts enjoy an afternoon on the golf course at the President's Cup Tournament.



## GBAHB REMODELERS' FISH FRY DRAWS OVER 100 FOR FOOD AND FELLOWSHIP

More than 100 members of the Greater Birmingham Association of Home Builders turned out for their recent Remodelers' fish fry, held at the GBAHB office. The annual event, which has taken place for more than 15 years, is planned and carried out entirely by the GBAHB Remodelers, who are responsible for everything from set up to cooking to musical entertainment to clean up. This year, Remodelers members George Williams, Roddy Sample and Mike Kelley served up fried fish, smoked salmon fillets and boiled shrimp to the attendees.

The fish fry has become a tradition that the GBAHB Remodelers look forward to as a fun night with great food and fellowship. It also serves as a recruitment tool as they reach out to non-members and encourage them to join.

GBAHB Remodeler member Roddy Sample serves up catfish at the Remodelers' annual fish fry.

## CULLMAN COUNTY SPORTING CLAY TOURNAMENTS BENEFIT SCHOLARSHIPS, ABPAC

The Cullman County Home Builders Association held two sporting clay tournaments on the same day to benefit two entities: their scholarship fund and ABPAC. The morning shoot was open to the public, with proceeds going toward the scholarship fund, while the afternoon shoot, open to CCHBA members only, supported ABPAC. Dr. Kevin Johnson won the morning shoot, while the team from Bill Hendrix Construction came in first in the afternoon event. The tournament was hosted by Maple Ridge Gun Club.



The team from Bill Hendrix Construction took the top prize at CCHBA's sporting clay tournament for ABPAC.



Dr. Kevin Johnson accepts his first place award for the sporting clay scholarship tournament from CCHBA President Willy Hendrix.

## SHOALS MEMBERS TEE OFF FOR SCHOLARSHIP ENDOWMENT FUND

Twenty-one teams participated in the Shoals Home Builders Association's annual Scholarship Golf Classic at the Blackberry Trail Golf Course. This year's tournament raised \$6,327 toward their Scholarship Endowment Fund, which they established in 2013 to help second year students studying the building trades at Northwest Shoals Community College.

The team from Southeastern Concrete Design placed first in the first flight, with the Classic Closets team coming in second. In the second flight, the team from Bama Concrete came in first, with the team from Progressive Lighting coming in second. Tyndal Davis and Billy Gamble won the Closest to the Pin, and Cody Hyde and Daniel Lorenzo won the Longest Drive.

Novelty prizes were also given to the teams who were "Best Dressed," "Not So Best Dressed," and "Highest Scorers."

Max Barnett of the Shoals HBA congratulates the teams from Southeastern Concrete Design (top) and Bama Concrete (bottom) on winning their respective flights at the SHBA's Scholarship Golf Classic.



## LOCAL CHARITIES BENEFIT FROM HMCB FOUNDATION

The Huntsville/Madison County Builders Foundation chose two local organizations to receive contributions from the Foundation this year. The Foundation's contribution to the Family Services Center will help support several of its homebuyer training programs, including Money and Credit Management, Home Shopping, Basics on Borrowing and Mortgages, Closing and Homeownership.

The Free Dental Clinic provides residents of Madison County with free extractions. The Foundation's contribution will go toward renovating the Clinic's new location.

H/MCB Foundation President Steve West presents Eugenia Graves, RN and Ginger Finzel, Executive Director of the Community Free Dental Clinic, with a check to be used for the new clinic's renovations.

## GREATER MONTGOMERY RUNS FOR HABITAT FOR HUMANITY

The Greater Montgomery Home Builders Association recently hosted its 2nd Annual Moonlight Dash 5K. Runners and walkers of all ages participated in the event, which also served as a fundraiser for Montgomery Habitat for Humanity.

This nighttime run featured a 5K race, a 1-mile pajama run, awards ceremony and post-race block party. The race began at the Jim Wilson Jr. YMCA in Montgomery, with nearly 220 participants in the 5K and nearly 40 in the 1-mile run. Thanks to community and member support the GMHBA was able to make a donation of \$2,500 to Habitat for Humanity.

In addition to the run, the Moonlight Dash featured a photo booth, sponsor tents, and various games and activities including a hula-hoop contest.

Runners line up at the starting line for the GMHBA's Moonlight Dash 5K.



## HUNTSVILLE'S ALLEN SELECTED FOR LEADERSHIP ALABAMA CLASS XXV

John Allen, President of Southern Construction & Design and a member of the Huntsville/Madison County Builders Association, has been selected to join Class XXV of Leadership Alabama for 2015. Founded in 1990, Leadership Alabama is a statewide nonprofit organization which brings together a class of 50 participants yearly with the objective to present the participants with a series of issues facing the State, and as they seek an understanding of these problems and priorities, they also seek to invent vital solutions to the challenges that define the future of our state. These members are selected based on their leadership abilities, career accomplishments, volunteer activities, contributions to the community and commitment to help shape a better Alabama.

John Allen

## BALDWIN COUNTY GOES FISHING FOR CARE HOUSE

The Baldwin County Home Builders Association and its Associate council held a Fishing Tournament to benefit Care House of Baldwin County. Anglers were allowed to weigh-in fish in three categories – Speckled Trout, Red Fish and Flounder. The weigh-in and presentation of awards was held at Big Daddy’s Grill on Fish River.



Robert Brown and Jake Markris show off their catches at the BCHBA’s fishing tournament.

The winners were as follows:

### SPECKLED TROUT

- 1st in total weight, 8.9: Robert Brown
- 2nd in total weight, 7.3: Jackson Roberds
- Lunker weight: W.C. Gafford

### RED FISH

- 1st in total weight & Lunker, 8.35: Derek Dobson
- 2nd in total weight, 8.10: Jake Markris

### FLOUNDER

- 1st in total weight, 2.95: Kevin Olmstead



Members of the HBAMM Remodelers present a check to the staff of Camp Rap-a-Hope at their annual fishing tournament.

## HBAMM REMODELERS REEL IN SUPPORT FOR CAMP RAP-A-HOPE

The Home Builders Association of Metro Mobile’s Remodelers’ 6th Annual Fishing Tournament was a great success, with enough money raised to feed an all-time high number of campers, counselors and staff at camp Rap-A-Hope as well as present the camp with a \$500 check. Camp Rap-A-Hope is an organization that provides year-long programming and a week-long summer camp to children between the ages of 7 and 17 who have, or have ever had, cancer.

The tournament winners were:

### RED FISH

- 1st – 8.19: KYLE WOODHAM
- 2nd – 6.49: Rick Tourne
- 3rd – 6.40: Trenny Woodham

### FLOUNDER

- 1st – 1.68: Kyle Woodham
- 2nd – 1.21: Michael Nicholas
- 3rd – 1.16: Jessica Owens

### SPECKLED TROUT

- 1st – 5.45: DARYL KINSLEY
- 2nd – 5.21: Cullen Jacobs
- 3rd – 4.89: David Stevens

### BAMA SLAM

- 12.18: Kyle & Trenny Woodham
- SPECKLED TROUT JACKPOT**
- 19.20: Kyle & Trenny Woodham

## H/MCBA MEMBERS APPOINTED TO CONSTRUCTION APPEALS BOARD

Three members of the Huntsville/Madison County Builders Association have been appointed to serve on the newly established Construction Appeals Board for the City of Madison. John Allen of Southern Construction & Design, Verrick Green of Green Roofing & Construction and T. J. Meers of Meers Construction will serve on this Appeals Board for five years.



## POOLE NAMED TRUSTEE EMERITUS FOR ALABAMA CENTER FOR REAL ESTATE

Bill Poole, a member of the Huntsville/Madison County Builders Association, has been named a Trustee Emeritus for the Alabama Center for Real Estate (ACRE)’s Advisory Board of Trustees. Poole, the founder of Bill Poole Realty, was instrumental in the creation of ACRE in partnership with the Alabama Association of REALTORS®, the Alabama Real Estate Commission, and the Culverhouse College of Commerce at the University of Alabama, where ACRE is housed. Established in 1996, ACRE serves to advance the real estate industry in Alabama by providing relevant resources in the areas of research, education and outreach.

Bill Poole

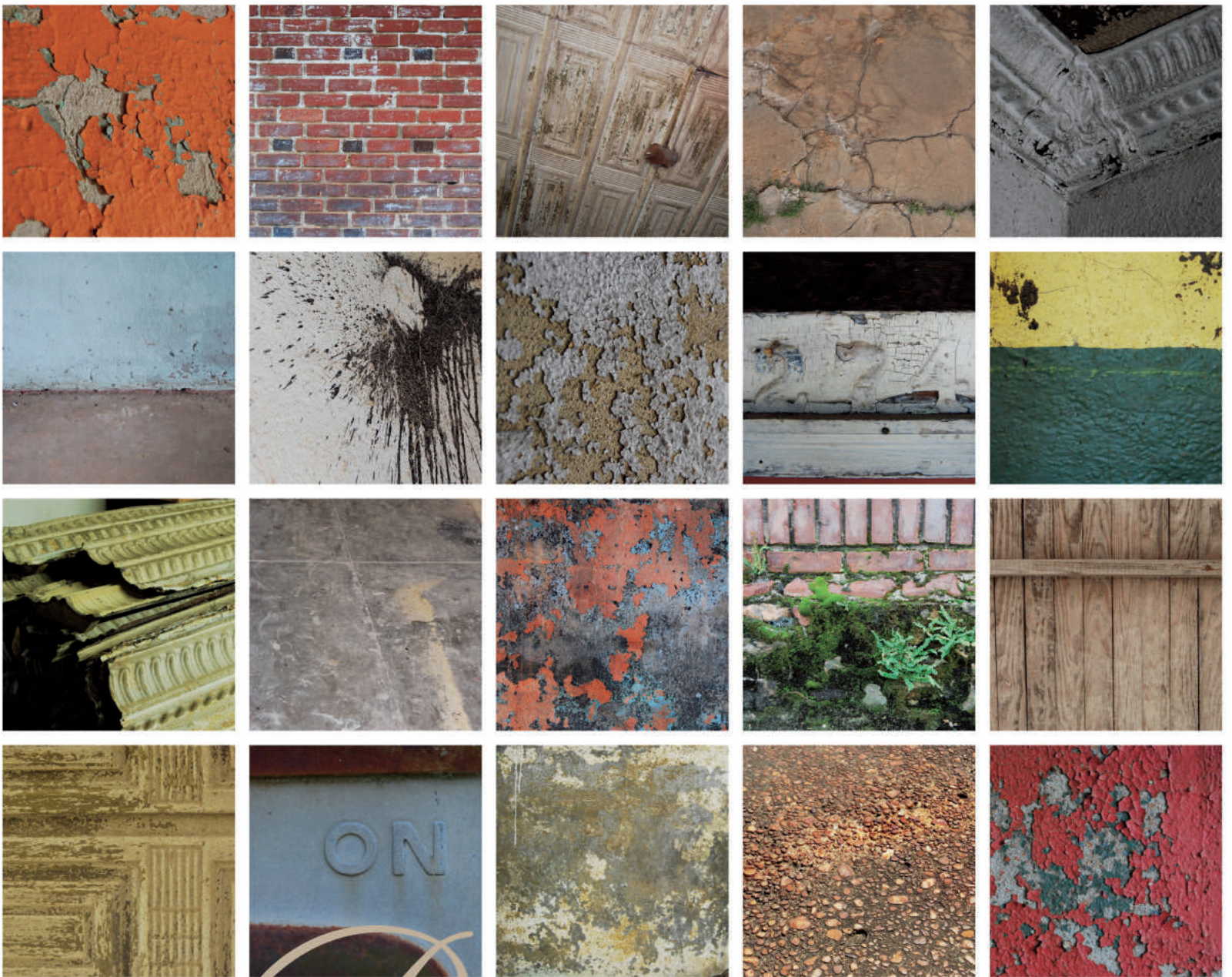

# *Rewriting* **HISTORY**

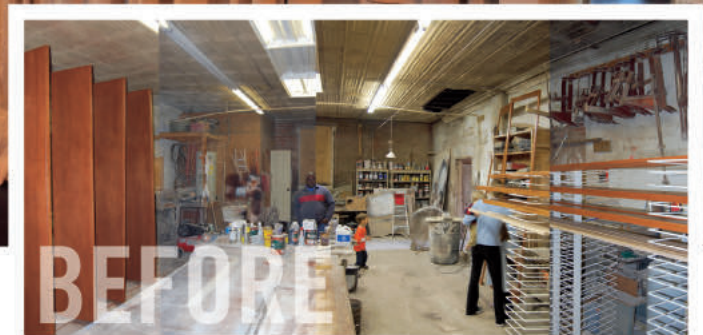
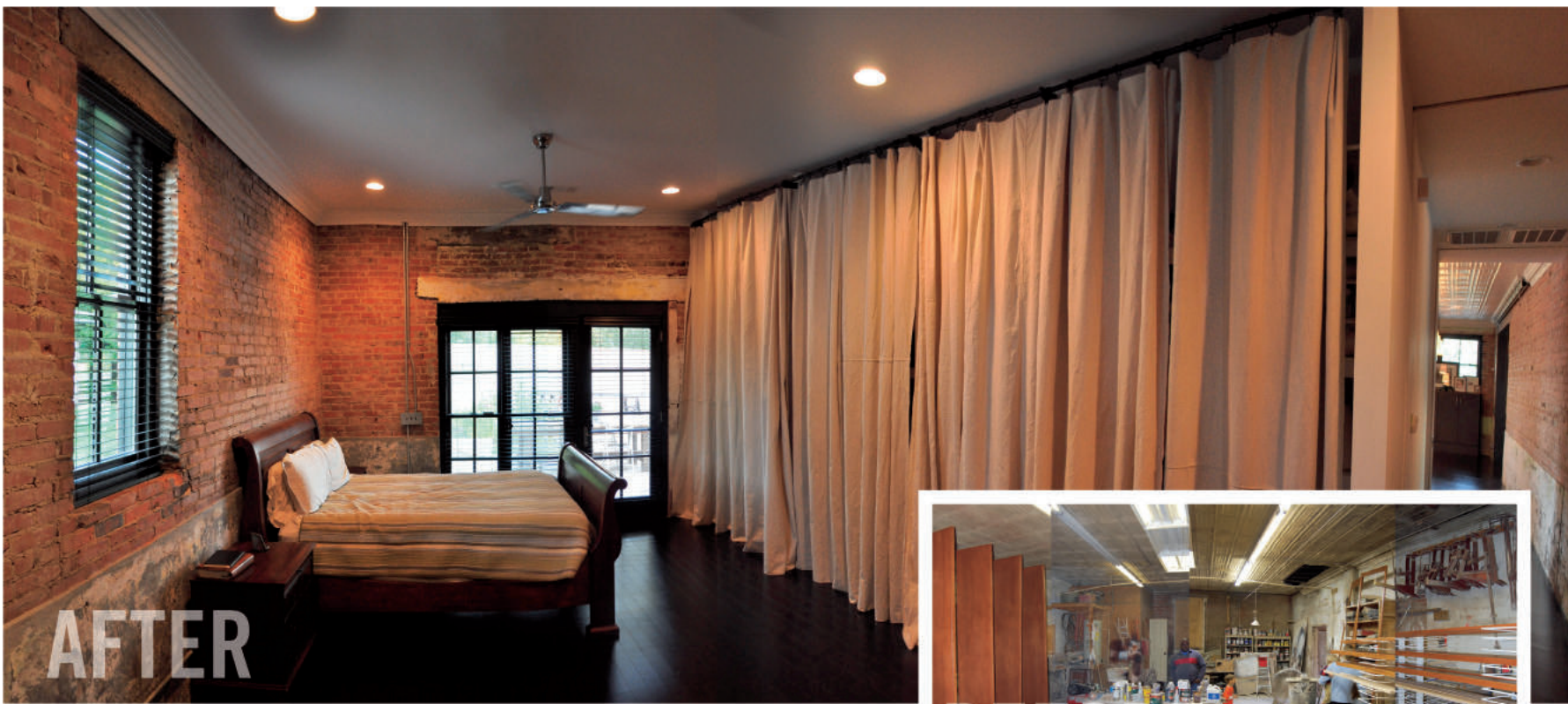

*(Top) Closets and storage space are grouped with the laundry and bathrooms to shield the bedrooms from the public areas. This bedroom formerly housed a cabinet shop.*

*(Above) The kitchen's original metal stamped ceiling tiles were removed, restored and rebung, and plaster replicas were created to fill in the missing corner pieces.*

*(Opposite) A variety of patinas and textures were revealed throughout the process of renovating the space, with many left exposed to highlight the structure's history.*

How do you transform a nearly century-old warehouse into a residence without losing the historic patina of the structure? That was the challenge faced by Lee County Home Builders Association member HF&L Construction, Inc. when the company was hired to turn this industrial building into a home for a young, growing family in downtown Auburn.

It was a challenge readily accepted by Greg Langston of HF&L, who was eager to get his hands on an historic structure. "I love history and I've always wanted to restore an older home, but most of the old homes in Auburn have been torn down," he said.

Located just a stone's throw from Auburn University, the building had been through many incarnations in its history. Built in 1920, it had housed at various times a pool hall, night club, grocery store, clothing store, cab company, recycling center, restaurants, a cabinet shop and even a church before its current turn as a dwelling.

"We were drawn to the idea of having large, generous spaces for the house," said homeowner David Hill. "We were in love with the brickwork when we saw the building. We really like how tough the building is. In general, the kids can be rough and tough and the building can handle it well."



*Designed to carry on the industrial feel of the home, the baths feature low flow fixtures and dual-flush toilets to conserve water.*

Hill, an architect and founding principal of HILLworks Landscape + Architecture as well as an assistant professor of landscape architecture at Auburn University, designed the renovation to fit his family's needs while keeping as much of the structure's history intact as possible.

"We didn't realize how amazing the history of the building is," said Hill. "We started researching the history, which we made publicly available [see end of article for details]. Once we found out that the building had such a rich background, we knew that we wanted to preserve the spirit of the structure. That spirit is not just the massive walls, but also the layers of paint on those walls. Each layer has a separate story to tell."

What was originally four separate commercial spaces was turned into an approximately 3,000 square-foot, four bedroom, two and a half bath home. The bathrooms, laundry, closets and storage were strategically situated to separate bedrooms from the home's public space, which incorporates an open-concept kitchen, dining and living area. Among the homeowner's favorite features are a huge, 1,000-pound sliding metal door that separates the two living areas and a garden on the east side of the home.

Along the way, care was taken to preserve and re-use certain elements of the original structure. The metal stamped ceiling tiles from 1920 were carefully removed, restored and rehung.



*Cutting large openings in the thick brick interior walls helped create an open flow between what used to be four separate commercial spaces.*





*The reclaimed garden, complete with a giant movie screen, allows the family to enjoy outdoor living.*

Plaster replicas were created to replace any missing corner pieces along the crown molding. Pads of impermeable concrete in the landscape were carefully cut, disassembled and reused, this time with their formerly concealed aggregates now exposed on the surface.

Langston is particularly proud of the restoration of the awning covering the south and west sides of the sidewalk. “It was in terrible disrepair, but we were able to restore it while keeping its historic integrity.”

In addition to preserving the home’s historic features, the design plan included several energy-efficient features, such as low flow fixtures and dual flush toilets in the bathrooms. Bamboo flooring was installed throughout. Rainwater is harvested from the roof and used in the garden.

“David [Hill] worked hard to take something old and antiquated and make it green,” said Langston.

The project was not without its challenges, considering not only the structure’s age but also its original use as four separate commercial spaces that had to be opened up and transformed into a single residential space. Much of the building had to be brought up to today’s code, a far cry from the way buildings were constructed a century ago. According to Langston, opening up solid brick and mortar interior walls that were eight to ten inches thick proved to be one of the greater challenges. Overall, the renovation took approximately six months to complete.

The project earned HF&L Construction the first-place award in the Historic Preservation category and second place in the Space Renovation category of the 2012 Alabama Remodeling Excellence Awards competition, presented annually by the HBAA’s Remodelers. The home has won several other awards, including a 2011 Award of Merit from the Montgomery Chapter of the American Institute of Architects (AIA), a 2012 Award of Merit from the Alabama Chapter of AIA, a 2013 Watermark Grand Award for its kitchen, and a 2013 Award of Merit from the Alabama Chapter of the American Society of Landscape Architects.

Founded in 1989, HF&L Construction specializes in custom and spec new construction as well as renovations. Although this was the company’s first historic renovation project, Langston hopes that it will not be the last.

**“This was such a big challenge, but it was so rewarding because it turned out so well. I’m really proud of it.”**  
– Greg Langston

*More photos from the project, as well as a detailed timeline of the building’s history and its transformation, may be viewed at [www.hillworks.us/bragg.html](http://www.hillworks.us/bragg.html).*

# CUSTOM-BUILT FOR OUR INDUSTRY



Since 1984, the Alabama Home Builders Self Insurers Fund has provided workers' comp coverage at competitive rates to qualified HBAA members. Thirty years later, we're still going strong with a variety of payment plan options, loss control experts to help you maintain a safe jobsite, and customer service that is second to none.

**Trust the workers' comp fund custom-built for our members,  
by our members.**



**Alabama Home Builders  
SELF INSURERS FUND**

**[www.AHBFund.com](http://www.AHBFund.com) / 1-800-745-3863**

# CELEBRATING 30 YEARS OF THE FUND:

## T H E B E G I N N I N G

*This October marks the 30th anniversary of the founding of the Alabama Home Builders Self Insurers Fund. Over the next year, each issue of Alabama Homebuilder magazine will feature an in-depth look at the Fund, from its humble beginnings to becoming one of the HBAA's most popular member benefits.*

The year 1984 turned out to be a pivotal year for the Home Builders Association of Alabama. With the industry slowly recovering from the abysmal housing slump of the early 1980s, many in the insurance market remained reluctant to provide coverage for residential construction. Finding workers' comp coverage at *any* cost, let alone at reasonable rates, was nearly impossible for many HBAA members.

In response to its members' needs for affordable coverage, the HBAA, led by then-President Jerry Kyser, took a leap of faith in forming the Alabama Home Builders Self Insurers Fund on October 1, 1984. A core group of 25 members stepped up to help form the Fund, which required a minimum of \$600,000 in contributions (better known as premiums in the insurance world). Many of those members took on not only the risk of a new program but also put up more money than they had to in order to meet the contribution requirement.

John Howard of Metro Mobile served as the Fund's first Chairman of the Board of Trustees. Fellow founding Trustees included Wayne Bonner (Huntsville/Madison County), Phillip Dutton (Jackson County), Robert Holk (Baldwin County), Don Nolan (Phenix City), Bentley Owens (Greater Birmingham), and Ted Watts (Greater Montgomery).

In the first year of its existence, the Fund grew to 645 members, with roughly a third of the HBAA's membership at that time participating in the Fund, and \$800,000 in contributions.

By the start of the 1990s, the Fund had 1,800 participants and \$12 million in contributions. Initially the management of the Fund was outsourced, but as it grew and matured it became increasingly apparent that it would be best run in-house. The first underwriting staff was hired in 1988, followed by accounting staff in 1992. In less than a decade, what had begun as a bold move to benefit members had clearly paid off, as the Fund was quickly becoming one of the biggest selling points of HBAA membership.

*To be continued in the next issue...*



*The Fund got its start under the leadership of these builder members who stepped up to serve as Trustees in 1984.*



When the Alabama Home Builders Self Insurers Fund was founded in October 1984, twenty-five HBAA members stepped up as its first participants. The following are the original Fund members, many of whom are still active in the Fund thirty years later.

- #001 - Government Street Lumber Co. (John Blacksher)
- #002 - John Howard Real Estate, Inc. (John Howard) \*
- #003 - Brewer, Balthrop & Howard Builders, Inc. (Pat Balthrop)
- #004 - Howard Brothers Construction, Inc. (Arthur Howard)
- #005 - Hudson Engineering & Construction Co., Inc. (Frank & Faye Hudson)
- #006 - Pierce and Howard Construction Co., Inc. (John Howard) \*
- #007 - Greater Montgomery Home Builders Association \*
- #008 - Home Builders Association of Alabama, Inc. \*
- #009 - Designs Unlimited, Inc. (Bob Cleland)
- #010 - Holk Builders, Inc. (Bob Holk)
- #011 - Nathan Watson Builder, Inc. \*
- #012 - Larry Tew Plumbing Company, Inc.
- #013 - J. B. Owens Realty Company, Inc. (Bentley Owens)
- #014 - Watts Homes, Inc. (Ted Watts, Sr.) \*
- #015 - Steeplechase Building Corporation (John Daniels and Wayne Bonner)
- #016 - Bricks, Inc. (Bill Nuntery)
- #017 - Nolan Construction Company, Inc. (Don Nolan)
- #018 - Don Hamilton Corporation
- #019 - Jerry Kyser Builder, Inc. \*
- #020 - Presentation Homes, Inc. (Tom Hearn)
- #021 - Rogers Paint Company (James Rogers)
- #022 - Jackson Gas & Electric Service, Inc. (John Jackson) \*
- #023 - Insulation & Old Brick co. (Harry Smith, Jr.)
- #024 - Hearn Plumbing Company, Inc. (Milton Hearn)
- #025 - AIC, Inc. (Donna Hays)

\* Still active

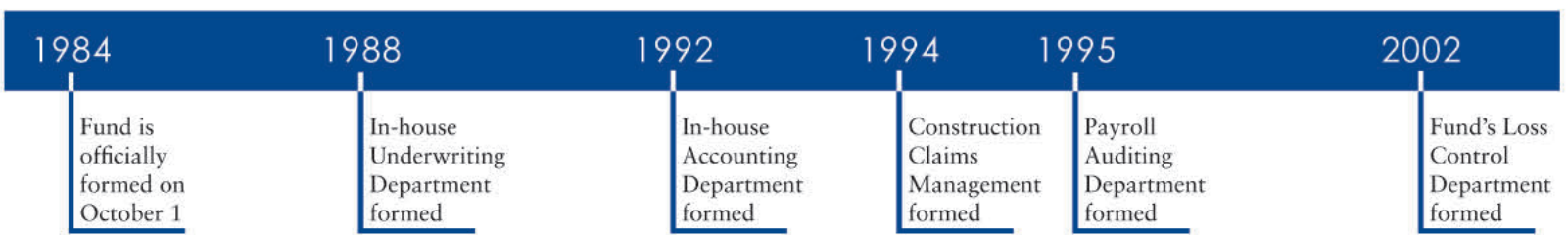

Associate members like Cathy Brown, pictured with HBAA President Les Letlow at the HBAA's Summer Meeting, say that getting actively involved at the local and state levels has been rewarding both personally and professionally.



## ASSOCIATE MEMBERS HELP DRIVE HBAA'S SUCCESS

The next time you're at a state or local HBA meeting or event, take a good look around. Odds are that the majority of the members in attendance are associate members. Of the more than 7,200 members in the HBAA, roughly 75% are associates. These include subcontractors, sales and marketing specialists, architects, interior designers, title and settlement experts, lawyers, people in the financial services industry, product suppliers and manufacturers, and many more who are essential to the challenging task of providing housing for a growing population.

Without the support and involvement of associate members, the HBAA and its local associations would not thrive. Many of our associates serve on councils and committees, sponsor events, advertise in publications, provide training and education, and help spread the message of the importance of Alabama's home building industry to the public.

"Associates are absolutely vital to the strength and growth of our association," said 2014 HBAA President Les Letlow. "Without their support, many of the events, education and services we provide would not be possible. It means a lot to me, as a builder member, to know that there are thousands of associate members who are in the trenches with me, investing their time and resources into this association and the home building industry."

Most associate members initially join for the opportunity to interact and do business with builder members. Will Brooks, an Alabama Power employee and a new associate member of the Lee County Home Builders Association, said, "I was anxious to get involved in the networking and seeing what the industry looks like from a homebuilder's perspective."

"As an associate member, participation has afforded me the opportunity to be in the position to form long-term friendships with builders, remodelers, and other associates," added David Estreicher of StyleCrest, a member of the Greater Birmingham Association of Home Builders. "Many of my builder and remodeler friends have also been very valuable business partners over the years. We have celebrated victories and worked through difficulties together. Many of my associate friends and I share opportunity leads, and pass each other's names on to assist our builders and remodelers to find the best business partners to work with and to allow them the opportunity to do business with a member first."

Many associates find that the benefits of being a member go far beyond the potential to earn new business, particularly when they become actively involved at the local and state levels.

"Being an associate member has increased my family members tremendously," said Peggy Turner, GBAHB member and owner of Graphic Designs & Promotions, Inc. "Who could say they just returned from the beach with 800 of their closest friends?"

"I have made some great friends and pulled through some great business deals by doing business with other members," said Cathy Brown of Alabama Power, a member of the Greater Montgomery Home Builders Association. "Getting involved is great fun and rewarding both personally and professionally. How could you be in the building industry and not be a member?"

Estreicher credits the friendships and connections made through his association membership with giving him a leg up on his non-member competition during the economic downturn.

"I am convinced that many of my GBAHB and HBAA builder and remodeler friends stayed loyal to me and purchased my products during the recession even in the presence of less expensive competitors, as we enjoy a common bond and hold ourselves to higher professional standards more so than just whom can provide the least costly widget," said Estreicher.

To honor their hardworking associate members, some of the local HBAs hold special events throughout the year. The GBAHB hosted an Associate Appreciation Night in September, which has been designated as National Associate Appreciation Month by the National Association of Home Builders. Associate members were treated to a tailgating party at the GBAHB office for the Auburn-Kansas State game, with plenty of food and door prizes. The event was sponsored by several of the GBAHB's builder members.

Likewise, the Shoals Home Builders Association hosts an annual Associate Appreciation Night featuring free food and door prizes for their associate members. Past events have included a football party and a low-country shrimp boil. The nights give builder members the opportunity to thank the associate members for the support that they provide.

Associate members who are already active at the local level are encouraged to come to the HBAA's meetings and get involved at the state level as well. The HBAA has long benefitted from a strong Associates Committee comprised of members who have been actively involved for years and who echo the sentiments of Turner: "As long as the good Lord lets me be able...I WILL be a participating member!"

If you would like more information about getting involved with the HBAA's Associates Committee, contact Artemis Moore at 1-800-745-4222 or email [artemismoore@hbaa.org](mailto:artemismoore@hbaa.org).



We've got the tools to meet your small group health insurance needs.

**Fully insured small group health insurance (2-100 employees)**

Administered by:



**Featuring:**

- Top rated insurance company
- Competitive rates and choice of PPO
- Choice of deductibles, co-payments and out-of-pocket limits
- Dental, vision and life insurance coverage
- Value-added tools and programs to help your employees become smarter consumers

**HSA and HRA Advantages:**

- Customer driven arrangements that save you money now!
- Simplified plan design makes the program easy to use
- Lower out-of-pocket costs compared to traditional PPO co-pay plans
- Promote employee involvement in managing healthcare costs
- Realize greater future rate stability

**For more information, call Builder Health Benefits  
334-271-0023, ext. 100 (Montgomery area) / 800-672-0023**

**BHB, INC.**  
Builder Health Benefits, Inc.

**NORANDEX  
THE WINDOW  
XPERTS**

**When it  
ABSOLUTELY POSITIVELY  
HAS TO BE RIGHT...**

As a trusted contractor to your customers, you have to be an expert in a lot of things. You have only one chance to get a window order right and that's why Norandex has become known as the place the Pros Go for windows. From innovative product designs to sales support programs, our window experts stand ready to help you find ways to sell more products and increase your bottom line. Don't take chances with your window projects, trust the window experts to get you the right products, at the right specs, on time, in full, at a fair price. *Trust Norandex.*

**VISIT ONE OF OUR LOCATIONS:**

**ANNISTON, AL 36207**  
(256) 831-1185  
(800) 239-9181  
FAX (256) 831-1383

**MADISON, AL 35758**  
(256) 461-7835  
(877) 511-8783  
FAX (256) 461-7933

**MOBILE, AL 36619**  
(251) 660-9002  
(800) 284-6390  
FAX (251) 660-9010

**MONTGOMERY, AL 36109**  
(334) 279-0501  
(800) 289-0501  
FAX (334) 279-0128

www.NORANDEX.com



**NAHB Members Save up to 36% With UPS®**

The National Association of Home Builders is proud to bring its members valuable discounts on the products and services you need. Make the most out of your membership and take advantage of some of the most competitive rates available on shipping services.

To save on your UPS shipments, simply:

Call: 1-800-MEMBERS (636-2377)

Visit: savewithups.com/nahb



# A WELL-FRAMED APPROACH TO PROFITABLE ENERGY EFFICIENCY

Changing codes, growth in the economy and housing starts – how's a builder to profit from it all? Well, a bottom-up switch to Norbord is a sound first move.



---

# BUILDING ALABAMA'S NEXT GENERATION WORKFORCE:

---

ALABAMA HOME BUILDERS FOUNDATION  
AWARDS SCHOLARSHIPS TO 80 STUDENTS

**E**ighty students from across the state will be better prepared to pursue careers in the home building industry, thanks to scholarships they received this year from the Alabama Home Builders Foundation. The Foundation, the charitable arm of the Home Builders Association of Alabama, annually awards scholarships to students desiring to study the building trades or construction-related curricula at two-year, four-year and technical colleges throughout the state.

The Foundation's scholarship program was established in 1997 in an effort to draw new tradespeople to the housing industry and to provide them with the tools and training needed to be successful. The majority of the scholarship funds come from proceeds from the Foundation Golf Classic, which is organized by the HBAA's Past Associate Committee Presidents and takes place each May.

In addition to providing scholarships from its general fund, the Foundation awarded several designated

scholarships this year. Gage Campbell of Killen; Robert Lewis of Bessemer; and Gerald Williams of Birmingham each received the Bentley Owens scholarship, given in memory of Bentley Owens, one of the founding members of the Home Builders Association of Alabama.

Recipients of Malone-McQueen scholarships included Zaccheus Jackson of Selma; Joseph Mims, Jr. of Montgomery; Jessie Shelton, Jr. of Selma; Ahmad Wilson of Tallassee; and Joshua Wright of Minter. The scholarship is given in memory of Charles and Mary Malone and William N. and Polly McQueen.

Any student wishing to study the building trades at a two-year, four-year or technical school in Alabama is eligible to apply for a scholarship. The scholarship deadline is March 15 and the recipients are announced in April. Scholarship applications are available online at [www.ahbfoundation.org](http://www.ahbfoundation.org), or students may call Artemis Moore, AHB Foundation Director, at 1-800-745-4222 for more information.

THE 2014

# ALABAMA HOME BUILDERS FOUNDATION SCHOLARSHIP RECIPIENTS

## BENTLEY OWENS SCHOLARSHIP RECIPIENTS

Gage Campbell (1)  
Killen  
Northwest Shoals Community College:  
Carpentry

Robert Lewis  
Bessemer  
Lawson State Community College: HVACR

Gerald Williams (2)  
Birmingham  
Lawson State Community College: HVACR

## MALONE-MCQUEEN SCHOLARSHIP RECIPIENTS

Zaccheus Jackson  
Selma  
Wallace Community College-Selma:  
Masonry

Joseph Mims, Jr.  
Montgomery  
Wallace State Community College:  
Masonry

Jessie Shelton, Jr.  
Selma  
Wallace Community College-Selma:  
Masonry

Ahmad Wilson  
Tallassee  
Wallace State Community College:  
Masonry

Joshua Wright  
Minter  
Wallace Community College-Selma:  
Masonry

## GENERAL FUND SCHOLARSHIP RECIPIENTS

Dustin Andrews  
Jacksonville  
Gadsden State Community College:  
Carpentry

Collin Andrews (3)  
Albertville  
Northeast AL Community College:  
Drafting and Design

Quentario Aull  
Tuscaloosa  
Wallace State Community College:  
Masonry

Aaron Baird (4)  
Alabaster  
Auburn University: Civil Engineering

Denardo Ballard  
Northport  
Shelton State: HVACR

Reginald Battles (5)  
Athens  
Tuskegee University: Civil Engineering

Brandon Bowman  
Rainbow City  
Gadsden State Community College:  
Electrical Technology

Joshua Brown  
Vinemont  
Wallace State Community College: Drafting  
and Design

Forrest Bryant  
Cullman  
Auburn University: Building Science

Shane Bursell (6)  
Hanceville  
Wallace State Community College: HVACR

Daniell Burton (7)  
Vestavia Hills  
University of Alabama - Tuscaloosa:  
Construction Engineering

Javier Canales  
Helena  
Jefferson State Community College:  
Architecture

Brandon Carter (8)  
Sumiton  
University of Alabama-Birmingham:  
Electrical Engineering

Megan Chesnut  
Anniston  
Auburn University: Building Science

Joshua Clark (9)  
Oxford  
Gadsden State Community College-Ayers:  
Electrical Technology

Allen Conradi  
Opelika  
Auburn University: Building Science

David Davidson (10)  
West Blocton  
Shelton State Community College: HVACR

Patrick Dreher (11)  
Pelham  
Auburn University: Landscape Design &  
Accounting

Gary Durbin (12)  
Auburn  
Auburn University: Building Science

Mary Dussett  
Sawyer ville  
Shelton State Community College: HVACR



Summer Faulkner  
Albertville  
Gadsden State Community College: Carpentry

Clay Gardner (13)  
Boaz  
Gadsden State Community College: Welding

Morgan Godwin (14)  
Gallion  
Auburn University: Civil Engineering

Preston Graben (15)  
Albertville  
Jacksonville State Community College: Civil Engineering

Blake Griffin  
Horton  
Wallace State Community College: Carpentry

Ryan Harbin (16)  
Florence  
Northwest Shoals Community College:  
Carpentry and Cabinetry

Gunnar Harden  
Foley  
University of South Alabama: Civil Engineering

Dewey Harrelson (17)  
Jacksonville  
Gadsden State Community College: HVAC/  
Plumbing/Electric

Stephen Hart (18)  
Oakman  
Bevill State Community College-Sumiton:  
HVACR

Ronald Hawkins (19)  
Birmingham  
Lawson State Community College: HVACR

Ryan Haymon (20)  
Arab  
University of Alabama: Electrical Engineering

Matthew Holland (21)  
Gadsden  
Gadsden State Community College:  
Electrical Technology

James Johnson (22)  
Eufaula  
Auburn University: Building Science

Darrin Jones (23)  
Birmingham  
Lawson State Community College: HVACR

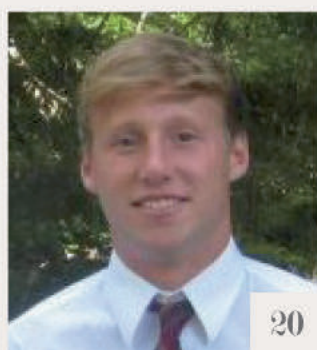
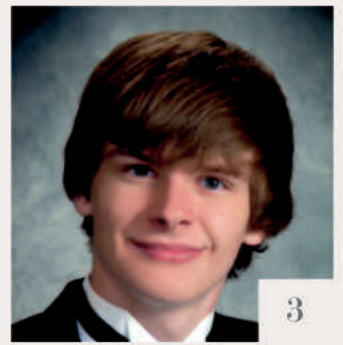

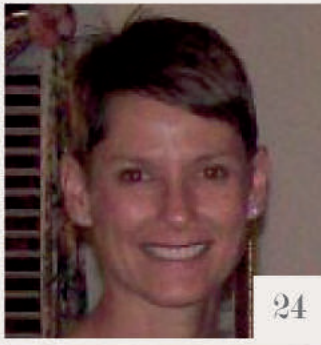

24



25

Denise Kalan (24)  
Dadeville  
Southern Union State Community  
College: Drafting and Design

Zackery Pasley (30)  
Fayette  
Bevill State Community College-  
Fayette: Electrical Technology



26

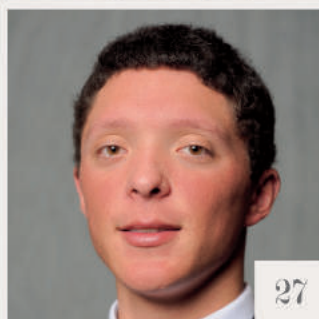

27

John Kampakis  
Birmingham  
University of Alabama  
Business

Richard Pate, Jr. (31)  
Lowndesboro  
Auburn University: Building Science

Jackson Laye (25)  
Sylacauga  
Auburn University: Building  
Construction

Gregory "Aaron" Pica (32)  
Joppa  
Calhoun Community College:  
HVACR

Martin Little (26)  
Moulton  
Calhoun Community College-  
Decatur: Electrical Technology/  
Industrial Maintenance

Heath Roeber (33)  
Huntsville  
Auburn University: Building Science

John Lutz (27)  
Fairhope  
University of Alabama  
Mechanical Engineering

Kayla Russian (34)  
Wetumpka  
Auburn University: Interior Design

Angelyn Martin  
Tuscaloosa  
Lawson State Community College:  
Building Construction

April Rutherford  
Leeds  
Jefferson State Community College:  
Carpentry



28

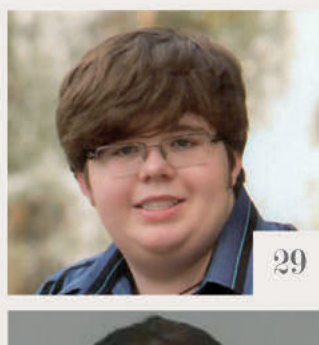

29

Samantha McCrary  
Stevenson  
Calhoun State Community College:  
Drafting

Jeremy Shirley (35)  
Luverne  
Lurleen B. Wallace Community  
College-Opp: HVACR



30

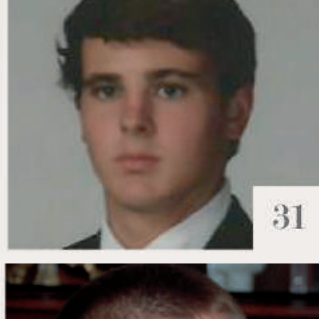

31

LaDravious Moncrief  
LaFayette  
Southern Union State Community  
College: Drafting and Design

Christopher Shore (36)  
Brookwood  
Lawson State Community College:  
Building Construction

Justin Nelson  
Muscle Shoals  
Northwest Shoals Community  
College: Cabinetry

Jacob Smith (37)  
Vinemont  
University of Alabama-Huntsville:  
Mechanical Engineering

Kaleb O'Neal (28)  
Grant  
Drake Technical College: Electrical  
Technology

Jerome Smith  
Opelika  
Southern Union State  
Community College: HVACR



32



33

Anthony Opsteen (29)  
Muscle Shoals  
Northwest Shoals Community  
College: Cabinetry

Mitchell Smith (38)  
Decatur  
Auburn University: Building Science

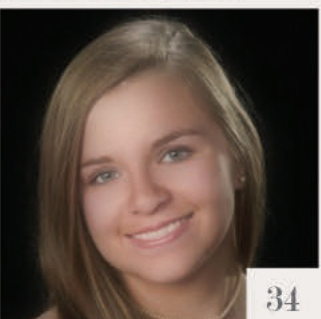

34



35



38



39

Jacob Sprinkle (39)  
Town Creek  
Northwest Shoals Community



36



37

College: Welding/Construction

John Stacey  
Semmes  
University of South Alabama:  
Civil Engineering

Warren Stewart (40)  
Albertville  
Auburn University: Business/  
Construction

Carolyn Taylor (41)  
Morris  
Wallace State Community  
College:  
Architecture, Design & Drafting

Timothy Taylor  
Vincent  
Jefferson State Community  
College:  
Building Construction

Jacob Thompson (42)  
McCalla  
Auburn University: Building  
Science

Willie Turner  
Birmingham  
Lawson State Community  
College:

HVACR

Katherine Uhrin (43)  
Oxford  
Auburn University: Architecture

David Weathersby (44)  
Birmingham  
Lawson State Community  
College:  
Building Construction

Blake Williams (45)  
Lexington  
University of Alabama -  
Huntsville: Civil Engineering

Devin Williams (46)  
Orange Beach  
Auburn University: Electrical  
Engineering

Joshua Williams  
Boaz  
Auburn University: Agriscience  
Education

David Wright  
Guntersville  
Auburn University: Civil  
Engineering

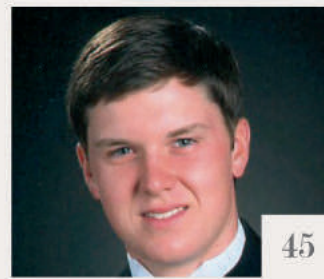
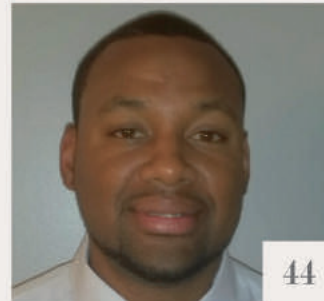
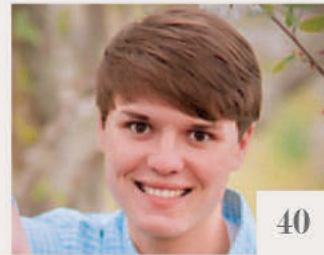

Collinsville, AL  
256.997.0703

“Once is not enough”



Makers of Fine Wood Flooring, Stair Parts, and Millwork  
from Recycled and Reclaimed Timbers

Visit us at: [www.jamesandcompany.com](http://www.jamesandcompany.com)



# You can try to ignore the risks, but not for long.

## **ALWAYS HIRE A CERTIFIED CONTRACTOR!**

It's a calculated risk to hire an uncertified contractor for plumbing or gas line installations. Not only could it be dangerous or costly, it can leave you with no recourse should the systems fail or prove inadequate.

Contractors certified by us are professionals who meet a set of standards designed to protect you and your investment.

So make sure. Visit our website to find a certified contractor near you.



**(205) 945-4857**

**State of Alabama Plumbers &  
Gas Fitters Examining Board**

11 West Oxmoor Road, Ste. 104

Birmingham, AL 35209

**[www.pgfb.alabama.gov](http://www.pgfb.alabama.gov)**

# LOCAL HBAs

SUPPORTING EDUCATION

## HUNTSVILLE/MADISON COUNTY BUILDERS ASSOCIATION

This year, the Huntsville/Madison County Builders Foundation presented scholarships in the amount of \$12,500 to 11 students pursuing careers in building-related fields. The recipients included:

- Jonathan M. Clark, studying architectural engineering at Tennessee State University;
- Edwin J. Derrick, studying electrical engineering Technology at J F Drake State Community & Technical College;
- Zackery M Dickens, studying welding at J F Drake State Community & Technical College;
- Zackary T. Duncan, studying electrical engineering at Alabama A & M University;
- Melvan M. Hayley, studying welding at J F Drake State Community & Technical College;
- Matthew T. Herrell, studying survey & geomatic Studies at Troy University;
- Cody I. McRae, studying welding at J F Drake State Community & Technical College;
- Alexandria J. Smith, studying business & construction management at the University of Alabama;
- Benjamin D. Stratman, studying civil engineering at Calhoun Community College;
- Kirby D. Tucker, studying architecture at Auburn University; and
- Dalton R. Turner, studying civil engineering at Mississippi State University.



Additionally, the Burl & Betty Chandler Scholarship Award was presented to Zackery Dickens and Melvan Hayley, both of whom will be studying welding at J F Drake State Community & Technical College.

Huntsville/Madison County BA scholarship recipients Melvan Hayley, Stephan Clark (accepting on behalf of his son, Jonathan Clark), Ben Stratman, Alexandria Smith, and Matt Herrell.

## GREATER BIRMINGHAM ASSOCIATION OF HOME BUILDERS

The Greater Birmingham Association of Home Builders' Educational Trust Fund Scholarship Committee awarded scholarships to 11 area students this year. The recipients included: Christopher Bradford, Shannon Brown, Larry Bryant, Toney Davis, Turwanda Middlebrooks, Michael Palmer, Charles Simpson and David Weathersby, all attending Lawson State Community College; Lauren Burks and Patrick Dreher, attending Auburn University; and Daniell Burton, attending the University of Alabama. Additionally, the GBAHB presented the Buddy Berry Scholarship to Patrick Dreher.

## CULLMAN COUNTY HOME BUILDERS ASSOCIATION

The Cullman County Home Builders Association presented several scholarships to local students, including Shane Dalton Bursell of Hanceville, Elijah Garrison and Braden Grant Walker.

Cullman County President Willy Hendrix and 2014 HBAA President Les Letlow present scholarships to Shane Bursell, Elijah Garrison and Braden Walker.



## GREATER MONTGOMERY HOME BUILDERS ASSOCIATION

The Greater Montgomery Home Builders Association's Professional Women in Building recently awarded the association's annual scholarship to Murry Clifton Rodgers. Rodgers, a recent graduate of Alabama Christian Academy in Montgomery, will be attending Mississippi State University, where he will study landscape architecture/construction. More than a dozen students submitted applications for the scholarship.

"We are so proud of Murry's educational accomplishments and look forward to seeing his continued success in college," stated Donna Young, PWB Vice-President.



PWB Vice-President Donna Young with scholarship recipient Murry Rodgers and his mother, Reena Rodgers.

---

## WALKER COUNTY HOME BUILDERS ASSOCIATION

The Walker County Home Builders Association presented several scholarships to area students this year, including Jaxon Aaron, Madison Lopez and Ricky Walton of Curry High School, and Madison Redmill of Walker High School.



Walker County HBA President Charlie Evans presents scholarships to Jaxon Aaron, Madison Lopez, Ricky Walton and Madison Redmill.



## GREATER GADSDEN HOME BUILDERS ASSOCIATION

The Greater Gadsden Home Builders Association presented a scholarship to Jaiwei Hong to study carpentry at Gadsden State Community College. He competed in the State Skills Carpentry Contest in April and finished second in the state.

Greater Gadsden HBA scholarship recipient Jaiwei Hong competes at the 2014 State Skills Carpentry Contest.

# MORE SAVINGS FOR YOUR SUCCESS.



2014 CHEVROLET SILVERADO 2500HD



2014 GMC SAVANA CARGO VAN



2014 BUICK LACROSSE WITH eASSIST

Example savings on a Silverado/Sierra 2500HD Crew Cab:

$$\begin{array}{ccccccc}
 \$1,000 & + & \$4,000 & + & \$1,000 & = & \$6,000 \\
 \text{Private Offer}^1 & & \text{National Fleet Purchase Program (FVX)}^2 & & \text{GM Accessory Cash Allowance}^{3,4} & & \text{In potential value}
 \end{array}$$

## Benefit from our private offer for NAHB members.

As the exclusive automotive manufacturer of the National Association of Home Builders (NAHB), we're pleased to extend association members a private offer<sup>1</sup> of up to \$500 toward the purchase or lease of most new GM vehicles. NAHB members who are business owners can now qualify for up to \$1,000 and also add on incentives from the National Fleet Purchase Program<sup>2</sup> and Business Choice<sup>3</sup> to get the best value on vehicles that run your business. To get this offer, just visit your local dealer, choose an eligible GM vehicle, and present your NAHB proof of membership form.

**For private offer details, visit [nahb.org/gm](http://nahb.org/gm).**

## New Brand Maintenance Plan<sup>5</sup>

Combine these great savings with our all-new 2-Year/24,000-Mile Brand Maintenance Plan<sup>5</sup> that covers scheduled oil changes with filter, tire rotations, and 27-point inspections, according to your new vehicle's recommended maintenance schedule.



<sup>1</sup>Private offer amount varies by model. \$500 offer for retail deliveries and up to \$1,000 offer for fleet deliveries. Valid toward the purchase or lease of eligible 2013, 2014, and 2015 model-year vehicles. Customer must take delivery by 1/2/15. Not compatible with other private offers. Not valid on prior purchases. Compatible with many current incentives. Incentives are subject to change without notice. Excludes Buick Regal [2014], Chevrolet Corvette [2014], Sonic, Spark, SS, Volt; all Cadillac models. FAN number required. See dealer for complete details.

<sup>2</sup>Offer eligible for non-CAP customers only through 12/31/14. See dealer for details.

<sup>3</sup>To qualify, vehicle must be used in the day-to-day operation of the business and not solely for transportation purposes. Must provide proof of business. For complete program requirements, including information regarding offers, vehicles, equipment, options, warranties, and ordering, consult your dealer or visit [gmbusinesschoice.com](http://gmbusinesschoice.com). Take delivery by 9/30/14.

<sup>4</sup>Not valid with all offers. See dealer for details. Take delivery by 9/30/14. Amounts include parts and labor.

<sup>5</sup>On select models starting with 2014. Eligible vehicles include purchased or leased new 2014 Chevrolet, Buick, or GMC cars, trucks, or crossovers in the U.S. Covers scheduled oil changes with filter, tire rotations, and 27-point inspections, according to your new vehicle's recommended maintenance schedule, for a maximum of four service events within 2 years or 24,000 miles, whichever comes first. Does not include air filters. Extra charge may apply for dual-rear-wheel tire rotations. See participating dealer for other restrictions and complete details.

©2014 General Motors. All rights reserved.

# EDUCATION

Dates and/or times and locations are subject to change if necessary. A course may be cancelled if minimum of 6 registrations are not received. Cancellation policy: To avoid course fee payment, registrants must give at least 48 hours notice to cancel. Registration required for all courses and tests. To register or for more information, contact Kory Boling at 1-800-745-4222 or koryboling@hbaa.org. Check the HBAA website calendar for the latest educational offerings: [www.HBAA.org](http://www.HBAA.org)

Whether you're looking to expand your business, save money or learn about the latest codes and regulations, the HBAA offers a variety of education around the state designed to meet your needs.

## CLASS LOCATIONS:

### BIRMINGHAM

Greater Birmingham AHB office  
5000 Grantswood Rd., Suite 240

### DOTHAN

Wiregrass Rehab Center  
795 Ross Clark Cir.

### HUNTSVILLE

Huntsville/Madison County BA office  
2804 Bob Wallace Ave.

### MOBILE

HBA of Metro Mobile office  
1613 University Blvd. S.

### MONTGOMERY

HBAA office  
7515 Halcyon Summit Dr., Suite 200

### SPANISH FORT

Five Rivers Delta Resource Center  
30945 Five Rivers Blvd., Blakely Hall

### TUSCALOOSA

HBA of Tuscaloosa office  
2009 Paul W. Bryant Dr.

## PROFESSIONAL DESIGNATIONS EDUCATION

DATE	COURSE	INSTRUCTOR	LOCATION
October 24	Profitable Business through Quality Practices	Benny Pritchett	Montgomery
December 12	Construction Contracts & Law	Tom Cooper	Montgomery

Professional designations classes will take place from 9 a.m. to 4 p.m. with lunch provided. Fees are \$225 for members and \$330 for non-members.

## QCI/STORMWATER EDUCATION

DATE	COURSE	LOCATION
October 21	QCI Initial Course	Mobile
November 11	QCI Continuing Ed	Huntsville
November 12	QCI Initial Course	Huntsville
December 3	QCI Continuing Ed	Montgomery
December 4	QCI Initial Course	Montgomery

QCI Initial Course Information: All initial courses will take place from 8 a.m. to 5 p.m. Cost is \$350 for HBAA members, \$500 for non-members and \$200 for government officials/non-certification participants.

QCI Continuing Ed Course Information: All continuing ed courses will take place from 12:30 p.m. to 4:30 p.m. Cost is \$100 per attendee.

\*Training will take place as part of the 2014 Alabama Clean Water Seminar & Field Days (October 8-9). Contact Kory Boling at 1-800-745-4222 or koryboling@hbaa.org for more information.

## LEAD PAINT RENOVATOR TRAINING

DATE	COURSE	LOCATION
October 23	Lead Paint Continuing Ed	Mobile
October 28	Lead Paint Initial Certification	Montgomery
November 17	Lead Paint Continuing Ed	Birmingham
December 9	Lead Paint Initial Certification	Montgomery
December 11	Lead Paint Continuing Ed	Montgomery

Lead Paint Initial Certification Training Information: All initial courses will take place from 8 a.m. to 5 p.m. Cost is \$125 for HBAA members and \$225 for non-members. You must be pre-registered to attend; no walk-ins allowed.

Lead Paint Continuing Ed Information: Under Alabama regulations, you must take a Lead Paint Certified Renovator refresher course every three years. Failure to take the refresher course prior to your expiration date will require that you retake the lead paint initial certification course. All lead continuing ed courses will take place from 12:30 p.m. to 4:30 p.m. Cost is \$75 for HBAA members and \$175 for non-members.

Contact Kory Boling at 1-800-745-4222 or koryboling@hbaa.org for more information.

## SAFETY 6 CONSTRUCTION COURSE

DATE	TIME	LOCATION
October 16	8:30 a.m.-4:30 p.m.	Spanish Fort
October 23	8:30 a.m.-4:30 p.m.	Montgomery
October 28	8:30 a.m.-4:30 p.m.	Birmingham
November 4	8:30 a.m.-4:30 p.m.	Tuscaloosa
November 13	8:30 a.m.-4:30 p.m.	Huntsville

The Safety 6 Construction Course is based on OSHA's 10-hour construction safety course but condensed into one day. It covers common residential and light commercial jobsite hazards and offers practical injury prevention measures, including information about products that can make jobsites safer and more productive.

The class also provides instruction on how to respond to an OSHA inspection, as well as guidelines and materials for developing an effective safety and health program. OSHA is pursuing more citations under the multi-employer rule, which can hold the builder accountable for the safety violations of subcontractors under certain circumstances. Builders can learn how to protect themselves from OSHA citations and penalties by attending this course.

Attendees will receive a manual on the course topics, a CD with numerous safety resources and a course completion wallet card. The cost is \$35 per person and covers course materials, snacks and lunch.

To register for one of the Safety 6 courses, contact Sherry Johnson at the Alabama Home Builders Self Insurers Fund at 1-800-745-3863 or email sherryjohnson@hbaa.org.





HOME BUILDERS ASSOCIATION  
OF ALABAMA

# Annual Convention

NOVEMBER 6-8, 2014



Make plans to join us at the  
Grand Hotel Marriott in Point Clear  
for our final statewide meeting of the year!

*All HBAA members and their guests are invited to attend.*



In addition to a variety of council and committee meetings, the Convention offers plenty of opportunities for education, networking and socializing. On Friday afternoon, you'll be able to enjoy a shopping excursion to Fairhope or join us at Oak Hollow Farm for a pheasant hunt.

Our Friday night banquet will salute outgoing HBAA President Les Letlow and welcome incoming leadership, as well as honor individual members and local associations with our annual awards presentation. We'll wrap up with the board meeting on Saturday morning to get you on the road and home or to enjoy the rest of the weekend on your own at the Grand.

To learn more or register, visit

[www.HBAA.org](http://www.HBAA.org)



For hotel reservations, call 1-800-544-9933  
(use group code HOBHOBA)  
or visit the HBAA website ([www.HBAA.org](http://www.HBAA.org))  
for the direct link to the  
discounted room rate website.

## Convention Sponsors

Alabama Gas Corporation  
Alabama Home Builders Self Insurers Fund  
Alabama Housing Finance Authority  
Alabama Power Company  
Azar & Azar, LLC  
Carlisle Medical, Inc.  
Construction Claims Management  
Morgan Stanley  
Servis 1st Bank  
UBS Financial Services, Inc.

I want to **BUILD**  
my **BUSINESS** with  
the highest quality materials  
and **SUPER** vendors.

**WITH  
BORAL  
YOU CAN.**



*Options  
for every style  
& budget*

**Boral Building Products**

**Alabama**

Florence: 256.764.9148

Gadsden: 256.546.5166

Huntsville: 256.721.0990

Pelham: 205.664.0257

Phenix City/Columbus: 706.322.9360

Build something great™

[boralbuildingproducts.com](http://boralbuildingproducts.com)

**Brick  
Stone  
EIFS and Stucco  
Trim and Siding  
Hardscapes**



C A L  
E N D  
A R HBA  
EVENTS

For details about these and other upcoming HBAA events, visit [www.HBAA.org](http://www.HBAA.org) and follow us on [Facebook.com/HBAAAlabama](https://www.facebook.com/HBAAAlabama).



**NOVEMBER 6-8**

HBAA Annual Convention  
(Grand Hotel Marriott,  
Point Clear, Alabama)



**JANUARY 16**

2015 Alabama Remodeling  
Excellence Awards registrations due  
Visit [www.RemodelAlabama.com](http://www.RemodelAlabama.com)  
for details.



**JANUARY 20-22**

2015 International Builders Show  
(Las Vegas, Nevada)  
Visit [www.buildersshow.com](http://www.buildersshow.com)  
for details.

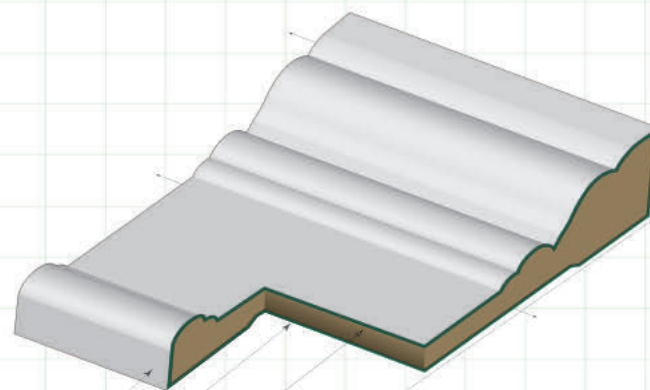

- Coating – Polymer ●
- Coated on All Four Sides ●
- Substrate – MDF ●

Finished Elegance® by Woodgrain is an interior moulding that is coated (**NOT PAINTED**) on all four sides resulting in easier installation and better wear and tear within a home.

— **Saves time and money**

# It pays to be a member of the HBAA!

In addition to benefits at the local and national levels, your HBA membership includes access to member benefits from the Home Builders Association of Alabama. Here are highlights of just a few of the many benefits that can help you save money and build your business!



## MEMBER REBATE PROGRAM

Exclusively for HBAA builder and remodeler members, our Member Rebate Program lets you earn money back on products you're probably already using on the jobsite. The program includes rebates from manufacturers such as Carrier, ClosetMaid, Delta Faucets, Honeywell, Owens Corning, Velux, and many more.

There's no paperwork to keep track of--simply register online and then file online for your rebate quarterly.

To learn more and to sign up, visit [www.hbarebates.com/hbaa.html](http://www.hbarebates.com/hbaa.html).



## BUILDERS HEALTH EXCHANGE

Have questions about choosing health insurance under the Affordable Care Act? We can help!

Our Builders Health Exchange site is designed exclusively for HBAA members to provide you with the information you need to help select the health coverage options that are best for you, your family and your company.

Visit [www.HBAA.org](http://www.HBAA.org) to access the Builders Health Exchange.



## BUILDERS RISK INSURANCE

The Home Builders Association Builders Risk Program is available to residential builders and remodelers who are HBA members in good standing. Coverage may be purchased through appointed agencies who are also HBA members.

For more information about the program, visit [www.HBABuildersRisk.com](http://www.HBABuildersRisk.com) or contact Helmut Mundt at 855-442-2467 or [helmut@hmia.com](mailto:helmut@hmia.com).

 HOME BUILDERS ASSOCIATION OF ALABAMA  
1-800-745-4222 | [www.HBAA.org](http://www.HBAA.org)

# Proud Sponsor of the Bubble Bath

## Natural gas water heaters...

- heat water up to twice as fast as electric water heaters.
- costs much less to operate than an electric water heater.
- work when the power is out.



We're the good heat.®

1-800-292-4010



 **Alagasco**

## 2014 HBAA EXECUTIVE COMMITTEE

### LES LETLOW

President

### BOBBY SMITH

National Director

### ALICIA HUEY

Presidential Appointee

### LYNN CORDER

1st Vice President

### DAVID LISEBY

Alternate National Director

### PHILLIP KINARD

Presidential Appointee

### MARK REID

2nd Vice President

### RANDY FANNIN

Alternate Associate Member  
National Director

### ROY JOHNSON

Presidential Appointee/  
IPOC Chair

### DAN TAYLOR

Treasurer

### PEGGY TURNER

Associate Member National  
Director

### JERALD SMITH

Regulatory Affairs Chair

### JIMMY RUTLAND

Secretary

### BLAKE CORDER

Governmental Affairs Chair

### MICHAEL TOLES

Affordable Housing Council/  
Building Innovations Group  
Chair

### KELLEY OUZTS

Associate Vice President

### KATIE MCLAUGHLIN

Professional Women in  
Building Area Trustee

### KEVIN PAKE

Education Committee Chair

### TAYLOR BURTON

Immediate Past President

### ROBERT BUCHALTER

ABPAC Chair

### TODD SLYMAN

Past State Presidents Chair

### ROBERT BROWN

Public Relations Chair

### MARK SALIBA

ABPAC Vice Chair

### PHEZA SUMNERS

Associate Committee Chair

### CATHY BROWN

Membership Team  
Representative

### CLIFF PITMAN

BUILD-PAC Trustee

### GEORGE WILLIAMS

HBAA Remodelers Chair

### LEE PAKE

Membership Retention  
Co-Chair

### TAYLOR BURTON

State Representative

### DARREN OSBORN

Past Associates Committee  
Presidents Chair

### SAM ALMAROAD

Membership Retention  
Co-Chair

### SONNY RICHARDSON

National Area VII Chair

### BEN BYRD

Presidential Appointee

### BUDDY BOWMAN

National Director

## HBAA STAFF

### RUSSELL DAVIS

CAE, BIAE, Executive Vice President  
russelldavis@hbaa.org

### DEBBIE BAXLEY

Administrative Vice President  
debbiebaxley@hbaa.org

### KORY BOLING

Education Director  
koryboling@hbaa.org

### SUZANNE HAGER

Administrative Assistant  
suzannehager@hbaa.org

### EVA HERNANDEZ

Administrative Support  
evahernandez@hbaa.org

### ARTEMIS MOORE

ABLE Marketing Director/  
AHB Foundation Director  
artemismoore@hbaa.org

### ERIN POOLE

Accounting  
erinpoole@hbaa.org

### BENNY PRITCHETT

Field Representative  
bennypritchett@hbaa.org

### JASON REID

Regulatory Affairs Director  
jasonreid@hbaa.org

### CANDI STROH

Web Specialist  
candistroh@hbaa.org

### LISA WATKINS

Public Relations Director  
lisawatkins@hbaa.org